



BS&B SAFETYSYSTEMS, INC.  
BS&B SAFETYSYSTEMS LTD.

# BURST ALERT SENSOR

## INSTALLATION INSTRUCTIONS

**BULLETIN  
77-1010I**

### CAUTION

Do not remove sensor from its package until it is required for installation. Handle the sensor with care. Do not fold, twist or stretch the sensor as this may break or weaken the conductive circuit and cause a false signal.

### SELECT PROPER LOCATION

Do not locate where the plastic membrane may be exposed to snow, ice, heavy rain or subjected to pressure or pressure evacuation in the vent piping.

Do not locate where the sensor to cable connection may be damaged resulting from bending or stress.

### BEFORE YOU INSTALL THE SENSOR

Examine the plastic membrane and conductive circuit before installing. Do not install if the circuit has been severed or if there is any damage to the plastic membrane. Insure that the size and pressure rating shown on the sensor are identical to those of the companion flanges.

The shape of the sensor matches the shape of Safety Head for easy alignment.

A sensor with a domed membrane is supplied for certain types of conventional tension loaded disks.

### INSTALLATION

The sensor is installed on the VENT SIDE of the rupture disk between the Safety Head outlet and the companion flange outlet. See Figure 1.

As the sensor is already fitted with hard compressed fiber gaskets no additional gaskets are necessary.

The sensor will function identically in either direction - cannot be installed incorrectly.

Follow the procedure as indicated in the rupture disk Installation Instructions and tighten the flanges stud nuts to the specified torque value.

### Sensors for VAC-SAF DKB, P/DKB and AVB Type Disks

The sensor is very fragile, avoid touching the sensor membrane. Do not exceed the torque values for 150 ANSI/DIN 10,16 flange ratings.

### Sensors for AV Type Disks

Adequate flange separation is required to avoid damaging the sensor. Do Not OVERTORQUE.

NOTE: At process temperature above 175° F (80° C) the torque value should be checked and if necessary the stud

nuts tightened to the correct torque value.

Do not locate cable on or near hot surfaces. Cable temperature specification -58°F (-50°C) to 194°F (90°C)

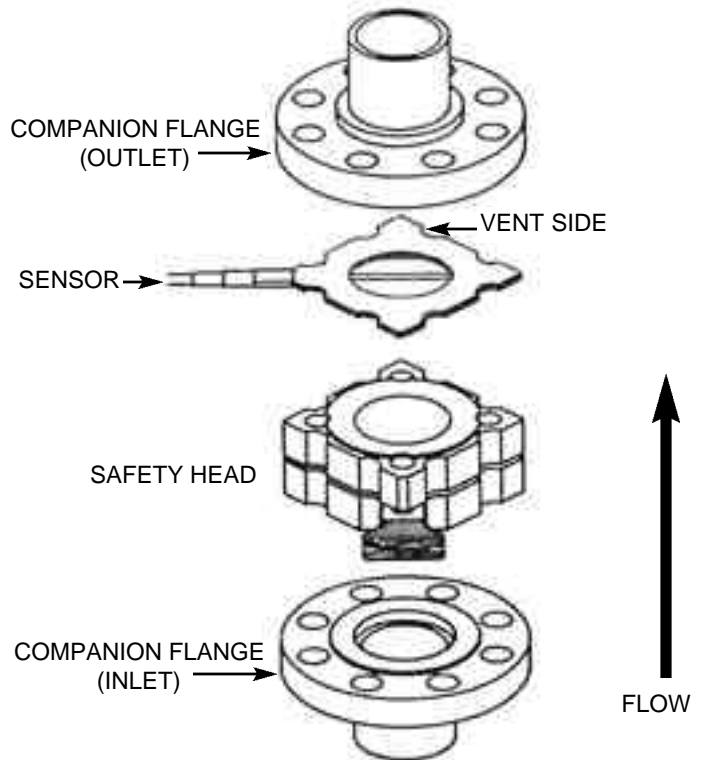

**FIGURE 1**

### ELECTRICAL SPECIFICATIONS

The rupture disk sensor is a simple device and is suitable for use in hazardous locations provided it is used with other certified electrical apparatus (i.e. Zener Barrier). All equipment should be installed and maintained to a recognized national standard.

Maximum Current 500 mA

Maximum Voltage 24VDC

### TEMPERATURE RANGE

#### Suitable for temperature

-40° F (-40° C) to 500° F (260° C) at the sensor location.

### PRESSURE RANGE

15 psig minimum. At burst pressures below 15 psig the disk may not provide a full relief opening.

### RE-ORDERING

Order replacement sensors by part number.

See our web site at [www.bsbsystems.com](http://www.bsbsystems.com) for updates

## LIMITATIONS OF WARRANTIES

BS&B Safety Systems, Inc. warrants its products against defective workmanship and material under normal and proper use in service for a period of twelve (12) months from the date of shipment, when owned by the original buyer and only when subject to normal operating conditions outlined by Buyer when the order is placed; except that, rupture disks are not guaranteed except to burst within specified pressure ranges at temperatures specified at the time of sale.

Where the products involved include a rupture disk inside a rupture disk holder, each must be of the proper type to be utilized with its mating part as otherwise recommended by and manufactured by BS&B. BS&B specifically disclaims any warranty and any and all liability for damages, either direct or indirect, incidental or consequential, arising from the use of rupture disk assemblies not wholly comprised of BS&B manufactured products.

Any article not manufactured by BS&B and which is sold hereunder is sold only under such warranties as the manufacturer thereof extends to BS&B and which BS&B can pass through to the Buyer and enforce with reasonable effort.

Because of the effects of corrosion or erosion caused by acids, chemicals, fumes, rust, dirt, debris and other factors of storage, use, and installation, over which BS&B has no control, BS&B makes no other warranties beyond those expressly stated in this limited warranty.

THE EXPRESSED WARRANTIES HEREINBEFORE GIVEN BY BS&B SAFETY SYSTEMS, INC. ARE EXCLUSIVE AND IN LIEU OF ALL WARRANTIES EXPRESSED OR IMPLIED, BY OPERATION OF LAW OR OTHERWISE INCLUDING, WITHOUT LIMITATION, ANY IMPLIED WARRANTY OF MERCHANTABILITY OR FITNESS FOR A PARTICULAR PURPOSE.



BS&B SAFETY SYSTEMS, INC.  
BS&B SAFETY SYSTEMS LTD.

BS&B Safety Systems, Inc. and BS&B Safety Systems Ltd. are here to assist you in providing a safe and efficient work place. For assistance on installation, audits, training or technical advice, please contact our Customer Service Department.

BS&B Safety Systems, Inc.  
7455 East 46th Street  
Tulsa, OK 74145  
Telephone: 918-622-5950  
Facsimile: 918-665-3904  
[www.bsbsystems.com](http://www.bsbsystems.com)

or

BS&B Safety Systems Ltd.  
Raheen Business Park  
Raheen, Limerick, Ireland  
Telephone: +353 61 227022  
Facsimile: +353 61 227987  
[www.bsb.ie](http://www.bsb.ie)