

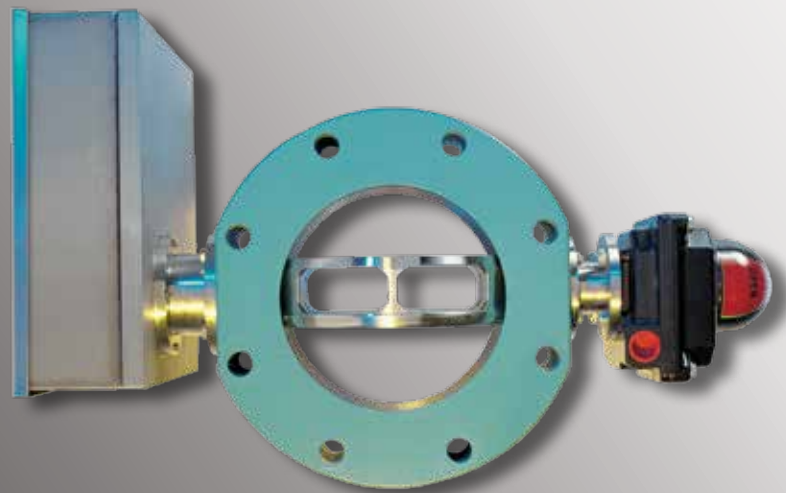

Buckling Pin Pressure Relief Technology

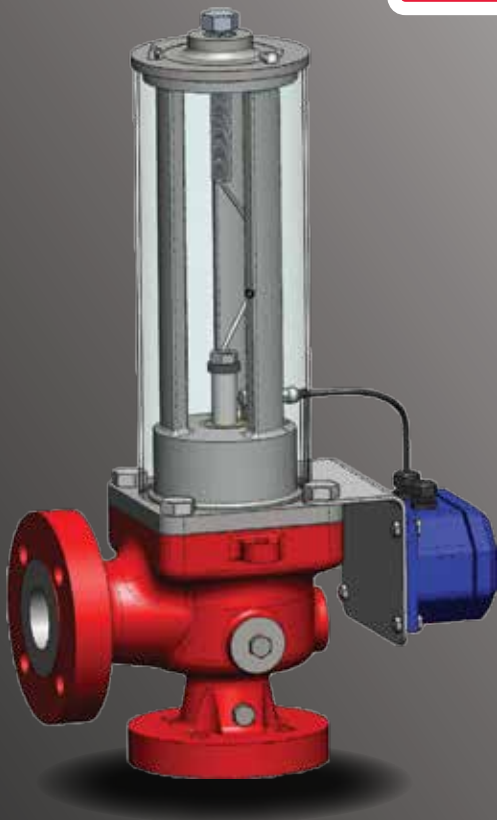

BSBsystems.com | BSB.ie

Visit our website for the most complete, up-to-date information

Specialty Valves

Buckling Pin Pressure Relief Devices

BS&B produces fast acting/quick opening buckling pin activated pressure relief devices (inline and angle discharge) designed to protect personnel, equipment and the environment from the dangers of overpressure. Buckling pin pressure relief devices combine the accuracy of rupture disks with the ability to be 'field-reset' while remaining installed after an overpressure event.

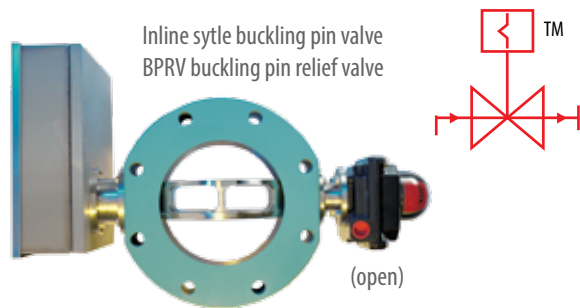

Patents 6367498, 6488044 and 6491055 apply

Features and Benefits

Buckling pin pressure relief devices provide practical technology for the protection of applications containing one or more of the following conditions:

- Continuous processing (fast reset in the line)
- Hazardous service (limits operator exposure)
- Large line size (convenient reset in the line)
- High flow capacity
- Inaccessible location (external reset in the line)
- High operating pressure to set pressure ratio
- Sizes from 1 inch (25mm) to 60 inches (1,500mm)
- Cryogenic designs available
- ASME "UD" stamped, section VIII, division 1
- European Pressure Equipment Directive "CE" marked
- Back pressure independent options available (BPiV™)

Operating Pressure Ratio

Buckling pin technology provides outstanding resistance to operating pressure conditions. The BPRV can be operated up to 95% of minimum set pressure. This is called the 'operating pressure ratio'. Subject to special testing, there is the ability to increase this ratio further.



Our Core Values

Innovation

We grow by being first with innovative products, solutions and services that are valued by our customers. Our employees pursue ingenious solutions in their roles and responsibilities.

Reliance

Our customers rely on us to deliver the best solutions and services. Our employees do the right thing and act with integrity, depending on each other working towards the success of the team and the company.

Excellence

We are committed to delivering high quality solutions and services that exceed expectations. We strive to be the best in everything we do through continuous improvement.

Respect

We inspire trust in our employees and gain trust from our customers by saying what we mean, matching our actions to our words.

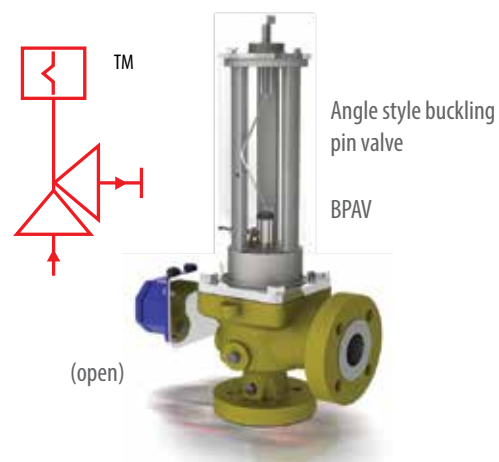

The BPAV™, BPRV™ and piping diagram icons are BS&B trademarks

Pressure Cycling Service

Buckling pin devices are well suited to cyclic service pressure conditions. Operating under compression, the buckling pin is not subject to tensile fatigue failure. The BPRV can be cycled to its maximum operating pressure ratio thousands of times.

US patent numbers 6,367,498; 6,488,044 and 6,491,055 apply; International patents apply and pending

BPRV™

Buckling Pin Relief Valve

The BPRV offers the highest flow capacity and convenient in-line installation. After activation, the valve is manually reclosed and the pin replaced while the valve remains bolted between pipe flanges. This dramatically reduces plant downtime and personnel exposure. The pin is accessible in a lockable enclosure containing the BPRV mechanism. Valve sizes range from 2 inches (50mm) to 60 inches (1,500mm). Alternative, larger sizes available upon request.



On the downstream side of the disk, there are two shaft connections that hold the disk freely within the body. These are also fitted with standard Fluoropolymer seals. Free rotation of the disk about the shaft is assured by the use of either bushings or bearings (depending upon size and set pressure) installed with a Fluoropolymer seal on either side. The shaft seals are not in process contact from the inlet side when the BPRV is in the closed position. (Alternate shaft seals are available upon request).

Size and Set Pressure Capability

The BPRV is available with a standard range of sizes and set pressures designed to suit applications that are compatible with ANSI 150, DIN PN 10 or similar flange specifications. In addition to these standard specifications, the BPRV is capable of meeting a wide range of dedicated customer requirements that have already included:

- High set pressures: Over 3,700 psi (255bar) in a 6 inch (150mm) nominal size installed between ANSI 900 flanges
- Low set pressure: 1 psig (68.9mbar) in a 24 inch (600mm) nominal size

Set Pressure Certification and Tolerance

In line with international standards, the BPRV is certified at the customer requested set pressure. This certification is a result of buckling pin tests being conducted in the BPRV to confirm compliance with set pressure and tolerance expectations. The BPRV is certified with a single set pressure tolerance, as indicated in the table below. For set pressures above 20 psi (1.4bar), the BPRV provides a superior set pressure tolerance of +/-5% compared to other non-reclosing pressure relief devices.

When certified according to ASME/North American standards, the BPRV is marked with the customer requested set pressure. When certified according to European (PED) standards, the BPRV is marked with the customer requested set pressure and the tolerance based upon the table below. Alternatively, European certification allows for marking the BPRV with a minimum/maximum set pressure (which will also be calculated from the table).

Pressure	Tolerance
From 1 - 40 psi (0.07-2.76bar)	±2 psi standard (0.14bar)
Over 20 psi (1.4bar)	±5% standard

Alternative tolerances available upon request
Please consult BS&B with your special applications

3 Set Pressure Calibration Controls

- **The offset of the BPRV disk shaft from the center line:** A large offset will generate a higher shaft load; a small offset will generate a lower shaft load. The BPRV is designed with the optimal offset based on set pressure requirements.
- **The buckling strength of the buckling pin:** This is a function of the 4th power of the pin diameter, the modulus of elasticity of the pin material, and the inverse of the pin length. Buckling pin diameter is used for significant set pressure tuning, length adjustment is used for fine tuning.
- **The enclosure mechanism uses a lever principal:** This enables a wide range of BPRV set pressures to be obtained with modest buckling pin lengths and diameters while using a disk shaft offset. This enables the mechanism to be compact and results in a simple pin installation procedure that can be completed by a single operator without special tools.

Note: The BPRV is calibrated before shipment to meet the users required set pressure and tolerance.

Materials of Construction

The user may specify the material of construction for each of the three major BPRV components, standard materials are as follows:

- **Valve body:** The standard materials are carbon steel and stainless steel. Alternate materials include duplex, super duplex, Hastelloy® C-276, Monel®, Inconel®, 625, titanium and metals that can be obtained in the form of cut plate or a forging (depending upon the size of the device to be fabricated)
- **Valve disk:** The minimum material is stainless steel. The disk provides the valve sealing surface, therefore a resistant surface must be ensured. Alternate materials are the same as for the valve body
- **Enclosure:** The standard material is stainless steel with Viton door seals. Alternates may be requested

Seals

The primary seal in the BPRV is mounted in the 1-piece body, held in place by a sealing ring. This seal engages a curved surface on the leading edge of the disk and has a profile that provides a tight shut-off from both the inlet and outlet sides of the device. The standard seal material is fluoropolymer (alternates are available upon request).

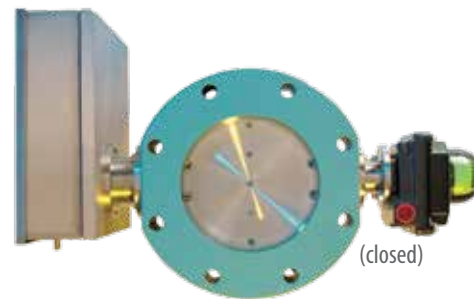

BPRV Valve in closed position

3 Primary BPRV Components

Rotating disk: A rotating disk normally closes the flow path and turns through 90 degrees in response to an overpressure/underpressure condition. The rotating disk is constructed from metal and has a hollow design. This maximizes the flow path through the BPRV and ensures the stability of the disk during normal service and at the time of opening.

Flanged body: A flanged body contains the rotating disk, holding it in place using shaft connections that are sealed within the body and pass through bearings to permit free rotation of the disk within the body. The body is a 1-piece design with no constructional welds or other potential external leak paths.

External enclosure and mechanism: The external enclosure and mechanism provides the set pressure control for the BPRV. The mechanism is designed to resist the turning moment of the disk shaft during normal service pressure conditions. When the desired set pressure is reached, the mechanism releases the disk due to the function of a buckling pin which has been built with sufficient strength to resist disk rotation until that point. The mechanism is contained within a stainless steel enclosure. The enclosure door includes a seal to permit service under severe environmental conditions.

Innovation

BS&B's 60 inch (1,500mm) BPRV, first released in 2007, is the world's largest ASME certified pressure relief device. Where variable back pressure is a concern, BS&B provides the BPIV™ (buckling pin independent valve) which is also available ASME certified. Both the BPRV and BPIV are available CE marked.

Temperature

The materials of construction for the BPRV permit a wide range of extreme service temperatures ranging from cryogenic to high-heat temperatures. Please review your temperature needs with BS&B. Each device has two different temperature considerations:

- Compatibility of service temperature with seal materials
- Buckling pin coincident temperature at time of function

Enclosure and Mechanism Construction

Three standard mechanisms are employed to meet the torque requirements of the BPRV nominal sizes 2-60 inches (50-1,500mm):

- M600 mechanism: low torque applications typical for sizes 2-6 inches (50-150mm)
- M4200 mechanism: Torque ranges typical for higher pressure 4 inch (100mm) BPRV devices through low pressure 24 inch (600mm) size
- M16000 mechanism: for high torque requirements of BPRV devices sized 20-60 inches nominal size

The mechanism front cover is provided with a latch tongue that aligns with another on the side to allow the user to add a preferred locking mechanism. Turn latches mounted on the front of the enclosure energize the door elastomer seal.

All mechanisms comprise of stainless steel and protective coated high tensile steel components. This combination avoids seizing of moving parts through the use of similar metals, and provides excellent corrosion resistance. The mechanism is fully sealed within the enclosure when the door is latched shut.

Customized BPRV Units/Command Activation

The BPRV can be command activated in two different configurations:

BPRV-CAE

If it is known that the BPRV will always sense a positive differential pressure, an actuator (e.g. solenoid or pneumatic piston) installed adjacent to the buckling pin can be used to buckle the pin on demand. This will release the BPRV mechanism and allow the disc to rotate freely under pressure.

This is known as a CAE (command activated enclosure) and allows the valve to be used as both a pressure relief device and a command actuated quick opening valve.

BPRV-CAS

If command actuation is desired in an application where positive differential pressure cannot be guaranteed, a powered actuator can be installed on the free shaft of the BPRV. When the operating conditions require the valve open, the actuator is powered to overcome both the buckling pin and any back pressure induced torque on the BPRV shaft to open the device.

This is known as a CAS (command activated shaft) and allows the BPRV to be used as both a pressure relief device and a command actuated quick opening valve.

The BPRV-CAE and BPRV-CAS are examples of customized design options that can be satisfied with this versatile pressure relief technology. BS&B welcomes the opportunity to develop solutions to unique applications.

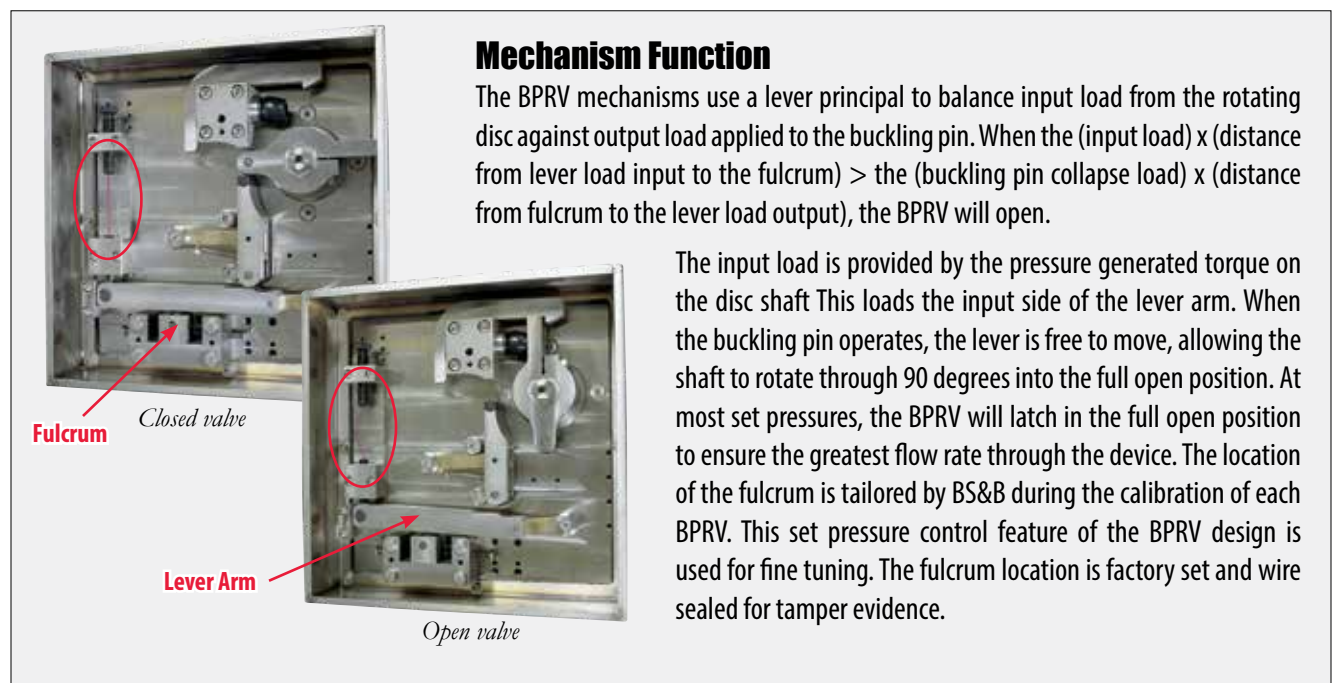

Mechanism Function

The BPRV mechanisms use a lever principal to balance input load from the rotating disc against output load applied to the buckling pin. When the $(\text{input load}) \times (\text{distance from lever load input to the fulcrum}) > (\text{buckling pin collapse load}) \times (\text{distance from fulcrum to the lever load output})$, the BPRV will open.

The input load is provided by the pressure generated torque on the disc shaft This loads the input side of the lever arm. When the buckling pin operates, the lever is free to move, allowing the shaft to rotate through 90 degrees into the full open position. At most set pressures, the BPRV will latch in the full open position to ensure the greatest flow rate through the device. The location of the fulcrum is tailored by BS&B during the calibration of each BPRV. This set pressure control feature of the BPRV design is used for fine tuning. The fulcrum location is factory set and wire sealed for tamper evidence.

Installation

The BPRV is designed for “in-line” installation between pipe flanges. Each device is a ‘full face’ design with the pipe flange bolting typically passing through the perimeter of the body. Some flange specifications have a compact bolting pattern that would interfere with the bushings or bearings if through bolt holes were used; in these cases, a threaded blind bolt hole is provided on both sides of the BPRV so a full set of flange bolts is installed. The piping may run horizontally, vertically, or at an oblique angle. The BPRV can be supplied set-pressure certified for any of these orientations. The user must identify the installation configuration at time of order to ensure appropriate calibration testing of the BPRV. The BPRV body can be fitted with lifting lugs to ease maneuver of the device into place between pipe flanges.

Field Reset

When a buckling pin has functioned and the BPRV is to be reset, this can typically be accomplished while the device remains installed in the piping system. The enclosure is opened, the used buckling pin removed, the disk rotated back into the closed position, a replacement buckling pin installed and the mechanism reset. This takes only a few minutes and can be completed by a single operator, even with the largest size BPRV.

Maintenance

As desired, the buckling pin can be removed and the BPRV tested by rotating the disk into the open position triggering the mechanism. There must be no pressure on the device. The buckling pin can then be reinstalled.

Occasionally it will be necessary to replace the main body seal. This can be accomplished quickly and easily. The main body seal is held in place by a seal retainer ring that inserts into the inlet of the one-piece body. This seal ring is simply removed, using simple tools, and the used seal pulled out from the BPRV body. After inspecting the seating area and clearing away any debris, the BS&B replacement seal is installed and the seal ring put back in place. Seal replacement does not require disassembly of the BPRV body or mechanism. It is recommended a spare main body seal is purchased for each BPRV.

BS&B Field Service

BS&B has a team of authorized technicians located around the world to support any field service requirements. BS&B can support our customers with installation supervision, commissioning, trouble shooting & repair service.

Testing In Place

Since the BPRV can be interpreted as a relief valve, many users wish to perform scheduled maintenance to ensure the set pressure has not been compromised while the valve is in service. The normal procedure for testing of many types of relief valves is to remove the valve from service and send to a valve repair shop for a pop test and re-certification. The advantage of the BPRV is that the valve can be re-tested in-situ. The offset shaft is designed with a hexagon drive in the enclosure. The user can leave the valve in service between the flanges and attach a torque wrench to the hex. All the user needs to do is remove the pin and load the shaft with a torque wrench until the valve opens. BS&B can supply a torque value range which, when applied to the hex drive of the offset shaft. Once the value recorded on the torque wrench lies within this torque range supplied by BS&B, the user knows that the valve set pressure has not been compromised and the product is now re-tested. This allows users to re-check the valve within 10 to 15 minutes, without having to remove it from the pipeline.

Testing in place greatly reduces the maintenance expenses compared with other relief valves by dramatically reducing the time and labor involved with the re-validation process. BS&B recommends these activities be supervised by a BS&B trained and authorized technician.



API 537 compliant application



US patent 6,484,742 and international patents apply

Optional Saf-T-Pin™ Buckling Pin Cartridge

The BPRV can be provided with buckling pin cartridges that are installed like an electrical fuse. The Saf-T-Pin buckling pin cartridge allows a “quick-change” option of buckling pins

with a simple push-in/pull-out design for installation within the enclosure. Each Saf-T-Pin cartridge contains a calibrated buckling pin that is perfectly mounted for optimum performance.

The Saf-T-Pin cartridge locks into the BPRV mechanism in one direction only, ensuring fail-safe installation. The transparent cartridge permits visual inspection of the buckling pin, and the stainless steel ends of the cartridge are marked with full set pressure and traceability information including the serial number of the BPRV device. The Saf-T-Pin cartridge avoids the need for special installation procedures and any concern of handling bare buckling pins.

Sensor/Indicator Option

Both a visual and electrical signal to confirm BPRV status is available. Mounted on the free shaft not used by the mechanism, the standard BPRV sensor comprises a sealed enclosure (typically to Nema IV standard) that houses a colored dome indicating ‘open’ (colored red) or ‘closed’ (colored green). The dome is rotated by a shaft extension that moves in unison with the disk of the BPRV. Electrical switching compatible with the users requirements can be added to the enclosure to provide a remote signal or alarm when the BPRV operates. This can be provided to meet intrinsically safe requirements.

SmartDisk™ Compatible

The BPRV can be supplied with SmartDisk wireless sensor technology that allows an electrical signal to be generated at a monitoring station located up to several thousand feet away from the BPRV without the cost of hard wiring.

Quality Assurance

Every BPRV is thoroughly tested before shipment. Pre-delivery inspection can be divided into:

- Dimensional inspection
- Leak tightness verification
- Buckling pin calibration and set pressure testing

Before the BPRV is assembled from component parts, each component is dimensionally verified for its critical features. After assembly the performance of the seals is checked, the Fluid Controls Institute specification is typically followed with a minimum test standard of class IV established. Many BPRV devices are supplied to the stricter class V and class VI limits which require a ‘bubble tight’ construction. The BPRV is third party certified by ASME and PED. Thus all standard valves can be ASME “UD” stamped and/or “CE” marked.

All buckling pins that are supplied as a lot are manufactured from a single batch of raw material at the same time. The BPRV set pressure is established through buckling pin destructive testing. Once the appropriate pin configuration has been achieved for the required set pressure, the lot of pins is completed within very tight dimensional tolerances. BS&B quality assurance personnel witness set pressure tests for certification purposes. All buckling pins are supplied tagged with a traceable lot number, set pressure and the serial number of the BPRV unit for which they have been calibrated. Saf-T-Pin™ buckling pin cartridges are recommended for optimum control and traceability.

When fully calibrated and certified, wire seals are installed at the following key locations:

- Junction of the body and the enclosure
- Fulcrum connection to the enclosure baseplate
- Junction of the sensor to the shaft (where fitted)

Codes and Standards

Several international standards recognize buckling pin devices and provide guidelines for their certification. These include ASME Section VIII, UG-138, TUV AD Merkblatt A1 and the European Pressure Equipment Directive (PED). The BPRV can be “UD” and/or “CE” marked.

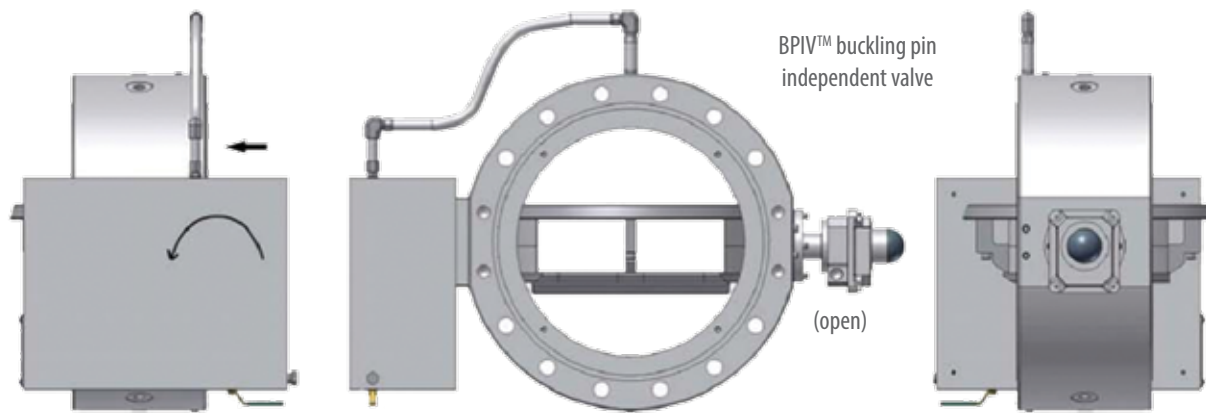

The BPIV is the same as the BPRV, but is back pressure independent

BPIV™ Buckling Pin Inlet Valve

The BS&B BPIV set pressure is controlled by a precision buckling pin which is calibrated to respond to the forces generated by inlet pressure acting on the valve disk independent of any back pressure that may be present. When the pin activates, the valve disk rotates to achieve a full diameter flow area. The BPIV has a soft seat. Standard valve materials are carbon steel and stainless steel for process contact components. Special materials are available upon request.



BPIV Buckling Pin Mechanism (Closed Position)

BPRV and BPIV Capabilities

Inlet size	Flow area	Set pressure range	ASME
2 NPS	2.75 sq in	15 - 2250 psi	VIII div 1
3 NPS	6 sq in	15 - 2250 psi	VIII div 1
4 NPS	10 sq in	15 - 2250 psi	VIII div 1
6 NPS	23.5 sq in	1 - 2250 psi	VIII div 1
8 NPS	39.65 sq in	1 - 2250 psi	VIII div 1
10 NPS	62.48 sq in	1 - 2250 psi	VIII div 1
12 NPS	90.5 sq in	1 - 2250 psi	VIII div 1
14 NPS	109 sq in	1 - 2250 psi	VIII div 1
16 NPS	149 sq in	1 - 1440 psi	VIII div 1
18 NPS	196.2 sq in	1 - 1440 psi	VIII div 1
20 NPS	239.1 sq in	1 - 1440 psi	VIII div 1
24 NPS	367.6 sq in	1 - 720 psi	VIII div 1
30 NPS	601 sq in	1 - 720 psi	VIII div 1
32 NPS	614 sq in	1 - 720 psi	VIII div 1
34 NPS	695 sq in	1 - 720 psi	VIII div 1
36 NPS	781 sq in	1 - 720 psi	VIII div 1
38 NPS	872 sq in	1 - 720 psi	VIII div 1
40 NPS	968 sq in	1 - 720 psi	VIII div 1
42 NPS	1069 sq in	1 - 720 psi	VIII div 1
44 NPS	1175 sq in	1 - 720 psi	VIII div 1
46 NPS	1286 sq in	1 - 720 psi	VIII div 1
48 NPS	1403 sq in	1 - 720 psi	VIII div 1
52 NPS	1650 sq in	1 - 720 psi	VIII div 1
54 NPS	1784 sq in	1 - 720 psi	VIII div 1
56 NPS	1918 sq in	1 - 720 psi	VIII div 1
60 NPS	2206 sq in	1 - 720 psi	VIII div 1

BPAV™ Buckling Pin API-Series Valve

The BS&B BPAV set pressure is controlled by a precision buckling pin that is calibrated to respond to the forces generated by inlet pressure acting on the valve plug. When the pin activates, the valve plug lifts to achieve a full diameter flow area. The BPAV has a soft seat. Standard valve materials are carbon steel and stainless steel for process contact components. Special materials are available upon request.

- The first API-526 piping configuration buckling pin valve
- 1 x 1.5 inches (25 x 40mm) to 8 x 10 inches (200 x 250mm); larger sizes available upon request
- Full bore relief for maximum flow capacity; 0.8 coefficient of discharge/ $K_d = 0.8$ for gas, $K_d = 0.686$ for liquid
- Fast acting
- Set pressure independent of back pressure, suitable for variable back pressure applications
- Operable to 90% of set pressure - no simmering
- Suitable for gas, liquid and two-phase flow
- Higher flow capacity than equivalent sized relief valve
- ANSI/ASME - EN/DIN - JIS and GOST flange compatibility
- ASME "UD" stamped, Section VIII, Division I
- Pressure Equipment Directive "CE" marked

Benefits

- Direct replacement of API series relief valves - no piping modifications
- Capacity of the BPAV exceeds the largest API size orifice per line size - $K_d = 0.8$ - ideal solution for brown-field projects; 0.686 for liquid
- More flow per line size than a relief valve
- Increased production capacity for same piping configuration
- Smaller size BPAV may be adequate for application
- Reducing valve cost, piping cost and weight - critical for offshore applications

BPAV-R™

Sharing the same configuration as the BPAV but with a replaceable seat - applied to corrosive and erosive application which may result in frequent seat replacements. Also applied to high H2S processes where the replaceable seat material needs to be of a higher alloy (eg. Inconel 625).

BPAV-LP™

Low set pressure buckling pin API series valve for set pressures below 25 psig (1.72bar).

Sizes

- 2 x 3 inches (50 x 80mm)
- 3 x 4 inches (80 x 100mm)
- 4 x 6 inches (100 x 150mm)
- 6 x 8 inches (150 x 200mm)
- 8 x 10 inches (200 x 250mm)

BPAV™ Capabilities

Inlet Size	Outlet Size	Flow Area	Orifice (Designator) Diameter	Set Pressure Range	Media	ASME
1 NPS	1.5 NPS	0.86 in ²	1.046 in	15-1440 psi	Air	VIII Div 1
1.5 NPS	2 NPS	2.04 in ²	1.612 in	15-1440 psi	Air	VIII Div 1
2 NPS	3 NPS	3.36 in ²	2.067 in	15-720 psi	Air	VIII Div 1
3 NPS	4 NPS	7.39 in ²	3.067 in	15-720 psi	Air	VIII Div 1
4 NPS	6 NPS	12.73 in ²	4.026 in	15-275 psi	Air	VIII Div 1
6 NPS	8 NPS	28.89 in ²	6.065 in	15-275 psi	Air	VIII Div 1
8 NPS	10 NPS	50.03 in ²	7.981 in	15-275 psi	Air	VIII Div 1

BPAV dimensions																			
in	mm	A		B		C		D		E		F		G		H		I	
		in	mm	in	mm	in	mm	in	mm	in	mm	in	mm	in	mm	in	mm	in	mm
1 x 1.5	25 x 40	26	660	0.9	24	1.0	27	4.9	124	1.1	29	1.5	38	6.1	155	4.1	105	4.5	114
1.5 x 2	40 x 50	31	787	1.1	29	1.6	41	6.1	155	1.3	32	1.9	49	6.5	165	4.9	124	6.0	152
2 x 3	50 x 80	31	787	0.9	22	2.1	53	6.5	165	1.1	29	2.9	74	8.3	211	5.4	136	4.9	124
3 x 4	80 x 100	36	914	1.1	29	3.1	78	8.3	211	1.3	32	3.8	97	10.0	254	6.1	156	6.4	162
4 x 6	100 x 150	36	914	1.3	32	4.0	102	10.0	254	1.4	37	6.1	146	12.5	318	7.8	197	8.3	210
6 x 8	150 x 200	46	1168	1.4	37	6.1	154	12.5	318	1.6	41	7.6	194	15.0	381	9.4	240	9.5	241
8 x 10	200 x 250	56	1422	1.6	41	8.0	203	15.0	381	1.9	47	9.6	243	17.5	445	10.9	276	11	279

BPAV and BPAV-R air/gas					
in	mm	Minimum burst pressure		Maximum burst pressure	
		psig	barg	psig	barg
1 x 1.5	25 x 40	15	1.03	1440	99.31
1.5 x 2	40 x 50	15	1.03	1440	99.31
2 x 3	50 x 80	15	1.03	720	49.66
3 x 4	80 x 100	15	1.03	720	49.66
4 x 6	100 x 150	15	1.03	275	18.97
6 x 8	150 x 200	15	1.03	275	18.97
8 x 10	200 x 250	15	1.03	275	18.97

BPAV and BPAV-R liquid					
in	mm	Minimum burst pressure		Maximum burst pressure	
		psig	barg	psig	barg
1 x 1.5	25 x 40	50	3.45	1440	99.31
1.5 x 2	40 x 50	15	1.03	1440	99.31
2 x 3	50 x 80	15	1.03	720	49.66
3 x 4	80 x 100	15	1.03	720	49.66
4 x 6	100 x 150	15	1.03	275	18.97
6 x 8	150 x 200	15	1.03	275	18.97
8 x 10	200 x 250	15	1.03	275	18.97

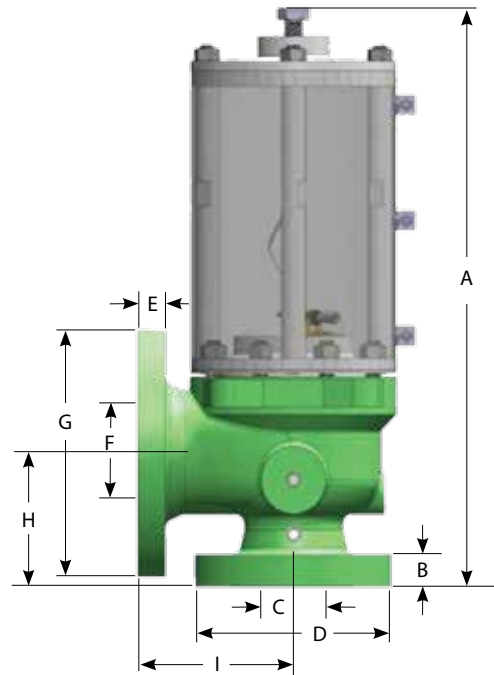

BPPV™ Buckling Pin Pilot Valve

The BPPV is a buckling pin pilot valve ranging from 6 x 6 inches through 30 x 30 inches (150 x 150mm through 1,220 x 1,220mm) with a set pressure from 10 to 275 psig (0.69 to 18.96barg). Larger sizes to 48 x 48 inches are also available.

Inlet size	Outlet size	Flow area	Orifice (designator) diameter	Lift	Set pressure range	Media	Code section
6 NPS	6 NPS	28.3 in ²	6.0 in	3.0 in	15 - 275 psi	Air	VIII div 1
8 NPS	8 NPS	49.0 in ²	7.9 in	4.0 in	15 - 275 psi	Air	VIII div 1
10 NPS	10 NPS	77.9 in ²	9.9 in	5.0 in	15 - 275 psi	Air	VIII div 1
12 NPS	12 NPS	110.9 in ²	11.9 in	6.0 in	15 - 275 psi	Air	VIII div 1
14 NPS	14 NPS	135.2 in ²	13.1 in	6.6 in	15 - 275 psi	Air	VIII div 1
16 NPS	16 NPS	179.1 in ²	15.1 in	7.6 in	15 - 275 psi	Air	VIII div 1
18 NPS	18 NPS	229.1 in ²	17.1 in	8.5 in	15 - 275 psi	Air	VIII div 1
20 NPS	20 NPS	285.3 in ²	19.1 in	9.5 in	15 - 275 psi	Air	VIII div 1
24 NPS	24 NPS	416.2 in ²	23.0 in	11.5 in	15 - 275 psi	Air	VIII div 1
30 NPS	30 NPS	658.7 in ²	29.0 in	14.5 in	15 - 275 psi	Air	VIII div 1



BPCV™ Buckling Pin Valve

Common Inlet and Outlet Connection Size

The BS&B type BPCV's set pressure are controlled by a precision buckling pin which is calibrated to respond to the forces generated by inlet pressure acting on the valve plug. When the pin activates, the valve plug lifts to achieve a full diameter flow area. The valves have a soft seat. Standard valve materials are carbon steel and stainless steel for process contact components. Special materials are available upon request.

Features

Angle valve design for connection to vertical inlet piping/ horizontal outlet piping

- Inlet and outlet flange connections for ANSI/ASME - EN/ DIN - JIS flange compatibility
- Same nominal size inlet and outlet connections, suitable for bypass applications
- Higher flow capacity than equivalent inlet size relief valve
- Operable to 90% of minimum set pressure
- Set pressure independent of back pressure provided inlet pressure exceeds back pressure

Standard BPCV Sizes

- 1 x 1 inch (25 x 25mm)
- 1.5 x 1.5 inches (40 x 40mm)
- 2 x 2 inches (50 x 50mm)
- 3 x 3 inches (80 x 80mm)
- 4 x 4 inches (100 x 100mm)
- 6 x 6 inches (150 x 150mm)
- 8 x 8 inches (200 x 200mm)

For individual valve dimensions, contact BS&B
Alternative sizes available upon request.



Edmonton, AB Canada

T: +1 780 955 2888
 F: +1 780 955 3975
 E: contacts@bsbprocess.com

Tulsa, OK USA

T: +1 918 622 5950
 F: +1 918 665 3904
 E: sales@bsbsystems.com

Minneapolis, MN USA

T: +1 952 941 0146
 F: +1 952 941 0646
 E: sales@bsbipd.com

Monterrey, Mexico

T: +011 52 81 1958 0560
 F: +011 52 81 1958 0560 138
 E: sales@bsbsystems.com

Houston, TX USA

T: +1 713 682 4515
 F: +1 713 682 5992
 E: sales@bsbsystems.com

Sao Paulo, Brasil

T: +55 11 2084 4800
 F: +55 11 2021 3801
 E: sales@bsbbrasil.com

**BSBSystems.com**

Visit our website for the most complete, up-to-date information

Manchester, UK

T: +44 0 161 955 4202
 F: +44 0 161 870 1086
 E: sales@bsb-systems.co.uk

Limerick, Ireland

T: +353 61 517000
 F: +353 61 309689
 E: info@bsbflamearrester.ie

Moscow, Russia

T: +7 495 747 5916
 F: +7 499 133 4394
 E: sales@bsbsystems.ru

Shanghai, China

T: +86 21 6391 2299
 F: +86 21 6391 2117
 E: sales@bsbsystems.com

Frankfurt, Germany

T: +49 6022 26 2310
 F: +49 6022 26 2311
 E: info@bsbsystems.de

Yokohama, Japan

T: +81 45 450 1271
 F: +81 45 451 3061
 E: information@bsb-systems.co.jp

The Netherlands

T: +31 70 362 2136
 F: +31 70 360 4724
 E: info@bsbsystems.de

United Arab Emirates

T: +971 2406 9603
 F: +971 2406 9810
 E: sales@bsbsystems.ae

Singapore

T: +65 6513 9780
 F: +65 6484 3711
 E: sales@bsb.com.sg

Chennai, India

T: +91 44 2450 4200
 F: +91 44 2450 1056
 E: sales@bsbsystems.com

BSB.ie

Visit our website for the most complete, up-to-date information

Products, specifications and all data in this literature are subject to change without notice. Questions regarding product selection and specifications for specific applications should be directed to BS&B. All sales are subject to the BS&B companies' standard terms and conditions of sale. Nothing herein should be construed as a warranty of merchantability or fitness for a particular purpose.